

KCSE PREDICTION 2018

PHYSICS PAPER 1 QUESTIONS

SECTION A (25 Marks)

Answer ALL the questions

1. Figure 1 below shows part of a micrometer screw gauge. Use the information and the figure to answer questions 1 and 2.

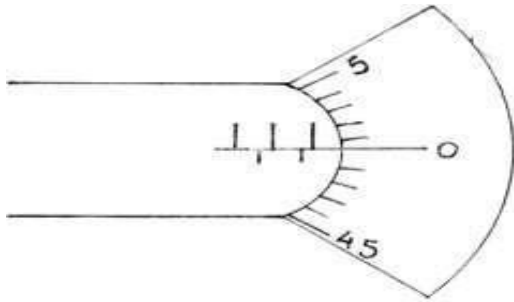

Figure 1

State the pitch of the micrometer screw gauge.

.....

2. What are the two limitations of the micrometer screw gauge.

.....
.....

3. State and explain any changes observed in a Brownian motion, when the temperature of the air in the smoke is increased.

.....

4. A wooden block of mass 2kgs is placed on a horizontal surface. A horizontal force of 12N is exerted on it makes it to accelerate at 5ms^{-2} . Find the frictional force acting between the surfaces.

.....
.....
.....

5. Sketch a velocity time graph for a body thrown vertically upwards to a maximum height.

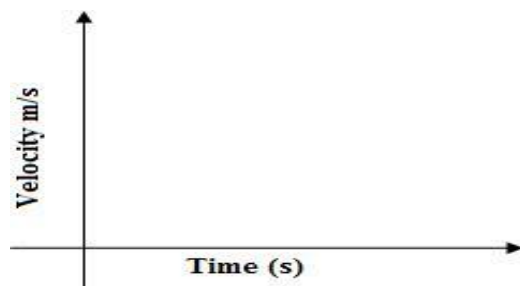

6. Lycopodium is lightly sprinkled on a clean water surface in a large tray. A red hot needle is

plunged into the centre of the water surface. State and explain the observation made.

.....

7. A tight rope walker carries a pole to maintain stability. Explain how he used it to achieve it.

.....

8. Figure 2 shows two set- ups by a student using identical lamps and thermometers.

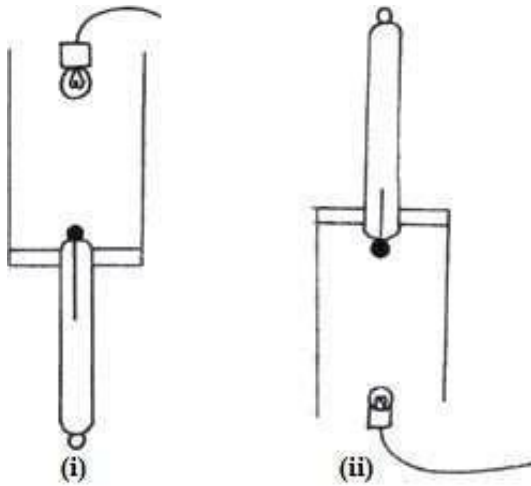

Figure 2

In which set up is thermometer reading a higher temperature, if the lamps are switched on for same duration?
 Explain

.....

9. Two table tennis balls are suspended from a support by thin strings and air blown between them as shown in figure 3 below.

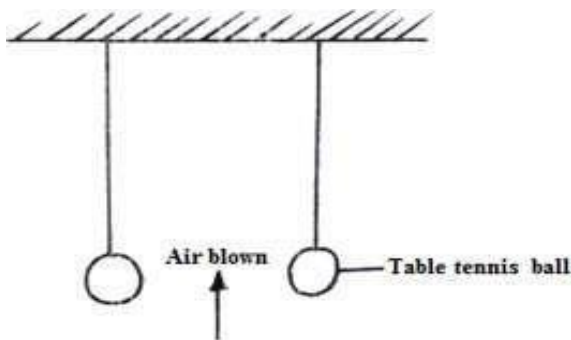

Figure 3

State and explain the observation

.....

10. Figure 4 shows a measuring cylinder half filled with paraffin.

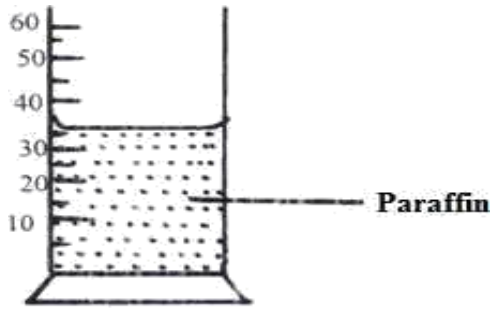

Figure 4

State and explain how the centre of gravity changes when a 10ml of water is added to the paraffin in the measuring cylinder.

.....

11. The system in figure 5 is a set up which can be used to illustrate expansion of liquids.

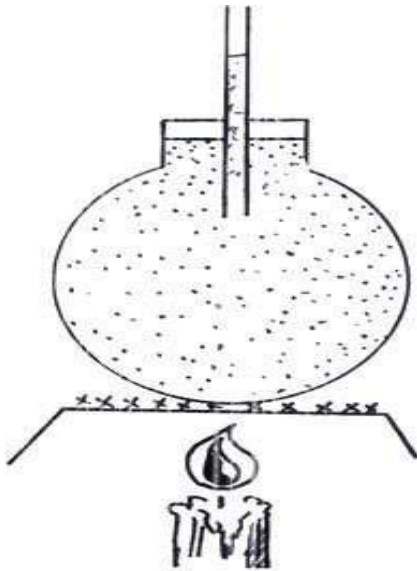

Figure 5

State one way of modifying the apparatus so that the rise in level for a particular temperature change is increased.

.....

12. Explain in terms of movement of molecules how the air exerts pressure on the inside surface of the tyre.

.....

13. Explain why pressure is more important than force when considering the damage which stiletto

heel might cause to floor

SECTION B (55 Marks)

Answer all questions

14. a) A light helical spring obeying Hooke's law was attached to a fixed support. When a 5N load was hung on it, the length of the spring was 160mm. When a 10N load was hung on it the length became 200mm. Determine

I. The length of the spring with no load

b) A car travels at a steady speed of 15m/s, the total resistance force (friction and air resistance) is 800N.

I) Determine the work done by the car in 10s in overcoming the resistance force.

II) Calculate the power developed at the driving wheel.

15. A balloon seller has a cylinder of helium gas which he uses to blow up his balloons. The volume of the cylinder is

0.10m^3 .

It contains helium gas at a pressure of

$1.0 \times 10^7\text{Nm}^{-2}$.

The balloon seller

fills each balloon to a volume of

$1.0 \times 10^{-2}\text{m}^3$

and a pressure of $2.0 \times 10^5\text{N/m}^2$

a) Calculate the total volume that the helium gases occupy at a pressure of (Assume

$1.2 \times 10^5\text{N/m}^2$.

the temperature of the helium does not change).

.....
.....
.....
.....
.....

b) Calculate the number of balloons of volume $1.0 \times 10^{-2}\text{m}^3$ that the balloon seller can fill using the gas.

.....
.....
.....
.....

c) The graph below in figure 6 shows how the pressure of a gas trapped inside a sealed container changes with temperature. The pressure is caused by the gas particles continually hitting the sides of the container.

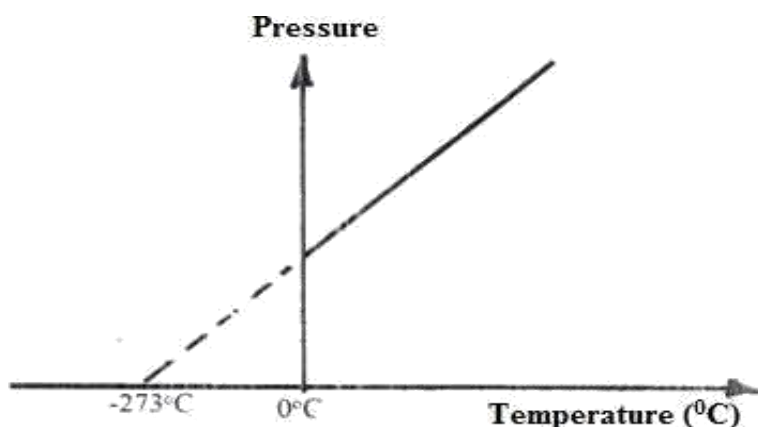

Figure 6

i) Write down the name of the temperature at which the gas particles stop hitting the sides of the container.

.....

ii) What is the momentum of the gas particles at this temperature? Give reason for the answer.

.....

iii) Give the value of the temperature in Kelvin

.....

16. a) Define term specific latent heat of fusion of a substance.

.....

b) Water of mass 400g at a temperature of 60°C is put in a well lagged copper calorimeter of mass 160 g. A piece of ice at 0°C and mass 40g is placed in the calorimeter and the mixture stirred gently until all the ice melts. The final temperature, T, of the mixture is then measured. Determine

i) The heat absorbed by the melting ice at 0°C ;

.....

ii) The heat absorbed by the melted ice (water) to rise the temperature T (Answer may be given in terms of T)

.....
.....
.....

iii) The heat lost by warm water and the calorimeter (The answer may be given in terms of T)

.....
.....
.....

iv) The final temperature T of the mixture (Specific latent heat of fusion of ice =334000J/kg, specific heat capacity of water = 4200J/kgK, specific heat capacity of copper =900J/kgK)

.....
.....

17. a) Figure 7 shows a pulley system

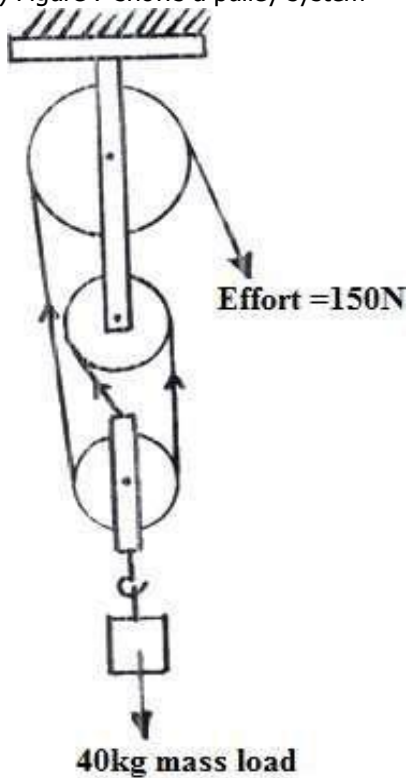

Figure 7

i) What is the velocity ratio of the system.

.....
.....

ii) Calculate the efficiency of the system.

.....
.....
.....
.....

iii) Give two reasons why efficiency is not 100%.

.....
.....
.....
.....

b) The graph below shows how a force applied on a 20kg mass varies with time.

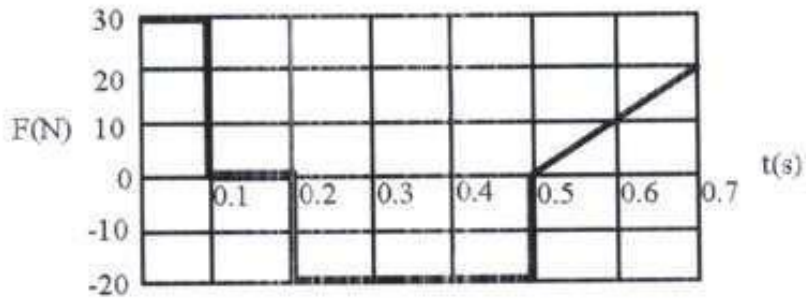

i) Find the impulse between 0.5s and 0.7s

.....

ii) If the body starts from rest, sketch an acceleration – time graph for the graph above. (Use the set of axes below)

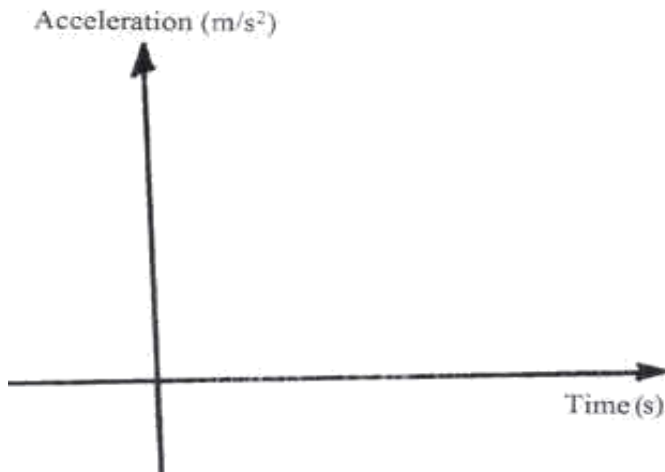

18. a) For a body moving with a constant acceleration, a , show that: i) $v = u + at$ where v and u are the final and initial velocities respectively while t is the time taken.

.....

ii) $S = ut + \frac{1}{2} at^2$ where S is the distance covered

.....

iii) A car of mass 1200kg moving at 90km/h is brought to rest over a distance of 20m. Calculate the breaking force.

.....

b) An object is projected vertically upwards with a velocity of 200m/s. Calculate:

i) Its velocity after 5 seconds.

.....

ii) The maximum height reached.

.....
